

DESCRIPTION

600 / 700 Series

The **600 and 700 SERIES** is a range of high performance diaphragm valves, suitable for Dust collector applications, in particular for reverse pulse jet filter cleaning of filter bags, cartridges, envelope filters, ceramic filters and sintered metal fibre filters. These valves, due to their inlet port larger than the outlet port, create a Venturi effect by causing a high flow rate at the outlet. The inlet is provided with a square flange designed for the coupling with a counter flange (optional) and stub pipe which are welded directly to the tank. The outlet is equipped with a quick connection fitting for the blow tube. The valves are constructed in die-cast aluminium and have an anodised protection treatment which protect them from corrosive and environmental agents. Bolts and screws are in stainless steel. The 600 and 700 Series are available in the following versions:

- VNP, with integrated solenoid pilot
- VEM, with remote pneumatic connection.



GENERAL CHARACTERISTICS		
Fluids	Filtered air and oil free	
Diaphragm	Standard NBR: -20°C / +120°C Optional Viton: -30°C / +200°C Nitrile: -40°C / +120°C	
	Pressure range	From 0,5 to 7,5 bar

CONSTRUCTIVE FEATURES - VALVE	
Cover	Die-cast aluminium (Anodised)
Body	Die-cast aluminium (Anodised)
Pilot Base	Brass (Chromed)
Pilot	Stainless Steel
Diaphragm	NBR
Bolts and screws	Stainless steel
Diaphragm Backing disk	Stainless steel
Diaphragm spring	Stainless steel

TYPE	Port Size Ø		N° Diaph.	Pressure Range (bar)		Weight Kg.	Coil	Kv	Cv
	IN	OUT		min.	max				
VNP608	2"	1"	1	0,5	7,5	0,55	YES	10	11,6
VNP708	2"	1 1/2"	1	0,5	7,5	0,65	YES	21	24,4
VNP614	2 1/2"	1 1/2"	2	0,5	7,5	1,4	YES	37	43,0
VNP714	2 1/2"	2"	2	0,5	7,5	1,5	YES	44	51,2
VNP616	3"	2"	2	0,5	7,5	2,5	YES	78	90,7
VNP716	3"	2 1/2"	2	0,6	7,5	3,3	YES	96	112
VNP720	3 1/2"	3"	2	0,6	5	7,55	YES	308	358
VEM608	2"	1"	1	0,5	7,5	0,25	NO	10	11,6
VEM708	2"	1 1/2"	1	0,5	7,5	0,35	NO	21	24,4
VEM614	2 1/2"	1 1/2"	2	0,5	7,5	1,1	NO	37	43,0
VEM714	2 1/2"	2"	2	0,5	7,5	1,2	NO	44	51,2
VEM616	3"	2"	2	0,5	7,5	2,2	NO	78	90,7
VEM716	3"	2 1/2"	2	0,6	7,5	3	NO	96	112
VEM720	3 1/2"	3"	2	0,6	5	7,2	NO	308	358

ELECTRICAL CHARACTERISTICS - SOLENOID	
Coil insulation	Class H
Din Socket Connector	Pg9 Connection
Din Socket Standard	EN175301 - 803 / A/ISO 4400
Din Socket Optional	94/9/CE ATEX II 3GD T6
Isolation class Din socket	VDE 0110 - 1/89
Electrical protection	IP65 EN60529
Voltage Range	12V DC (-5%, +20%) 12W
	24V DC (-5%, +20%) 12W
	48 V DC (-10%, +20%) 9W
	110 V DC (-10%, +20%) 12W
	24V 50/60Hz (-10%, +20%) 16/12 VA
	48 V 50/60 Hz (-10%, +20%) 16/12 VA
Ambient temperature	110/127 V 50/60 Hz (-10%, +20%) 19/14 VA
	220/240 V 50/60 Hz (-10%, +20%) 19/14 VA
Ambient temperature	-20°C / +60°C

HOW TO ORDER:

VEM/VNP 6 08 110/50

VNP: with integral pilot
VEM: without pilot

6: 600 SERIES
7: 700 SERIES

VALVE CONNECTOR DIAMETER
• 08 = 1" - 1 1/2"
• 14 = 1 1/2" - 2"
• 16 = 2" - 2 1/2"
• 20 = 3"

Voltage and frequency required.

DIMENSIONS

600 / 700 Series

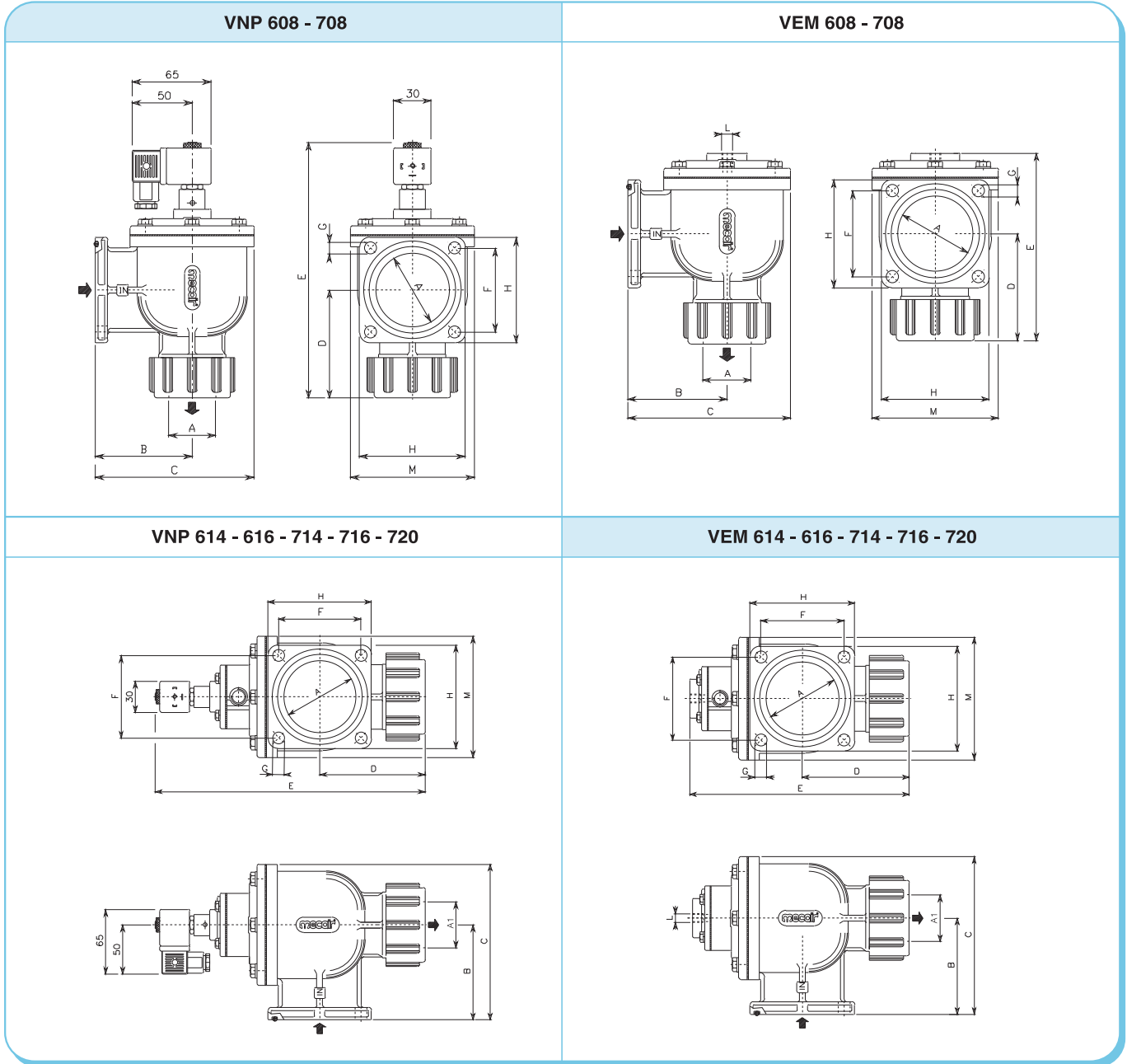

MODEL	Ø A	Ø A1	B	C	D	E	F	G	Ø H	M	Weight Kg.	MODEL	E	Ø L	Weight Kg.	N° Diaph.	O-Ring
VNP 608	2"	1"	81	125	110	225	60	9	83	90	1,5	VEM 608	180	1/4"	1,2	1	OR6250
VNP 614	2 1/2"	1 1/2"	96	160	130	305	72	11,5	95	140	2,2	VEM 614	245	1/4"	1,9	2	OR178
VNP 616	3"	2"	110	185	140	330	85	13,5	110	165	2,8	VEM 616	270	1/4"	2,5	2	OR6350
VNP 708	2"	1 1/2"	81	125	110	255	60	11,5	83	90	1,5	VEM 708	180	1/4"	1,2	1	OR6250
VNP 714	2 1/2"	2"	96	160	130	305	72	13,5	95	140	2,2	VEM 714	245	1/4"	1,9	2	OR178
VNP 716	3"	2 1/2"	110	185	140	330	85	13,5	110	165	2,8	VEM 716	270	1/4"	2,5	2	OR6350
VNP 720	3 1/2"	3"	125	215	165	360	94	13,5	120	190	3,7	VEM 720	300	1/4"	3,4	2	OR189

SPARE PARTS

600 / 700 Series

VEM / VNP 608 - 708

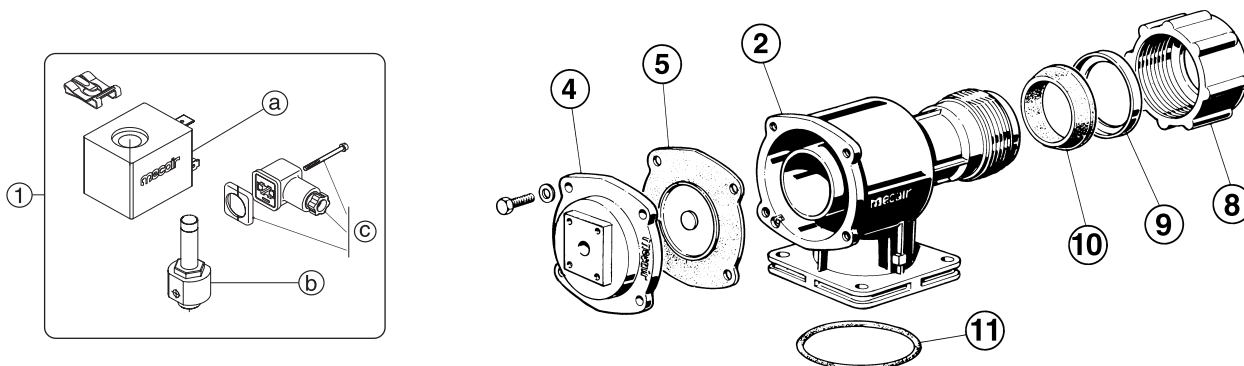

VEM / VNP 614 - 714 - 616 - 716 - 720

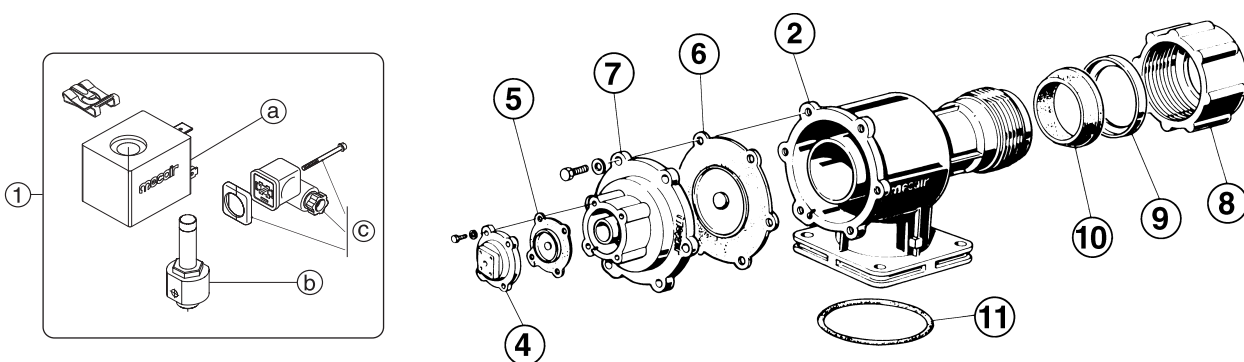

* Code for Spring M470568 for model VEM / VNP 612 - 712 - 614 - 714 - 616 - 716 - 720

STANDARD Version

Standard	POS	DESCRIPTION	CODE
	1	a) Solenoid (*) b) Pilot group complete with base and ferrule c) Din Connector PG9EN175301-803 IP65	a) SB3 - ../.. (*) b) CP1/4 c) PLG9

(*) Specify Voltage and Frequency

OPTIONAL Version

Optional	POS	DESCRIPTION	CODE
	1	a) Solenoid b) Pilot group complete with base and ferrule c) Din Connector (3GD IP65 T6)	a) SB3 - 24/DCX b) CP1/4 c) PLG9 - ATEX

Version in conformity to European Directive 94/9/CE ATEX (cod. PV-24/DCX)

POS	DESCRIPTION	CODE						
		VEM/VNP608	VEM/VNP708	VEM/VNP614	VEM/VNP714	VEM/VNP616	VEM/VNP716	VEM/VNP720
1	Pilot group complete with solenoid (*) and din connector	PV - ../.. (*)	PV - ../.. (*)	PV - ../.. (*)	PV - ../.. (*)	PV - ../.. (*)	PV - ../.. (*)	PV - ../.. (*)
1+4	Pilot group complete with solenoid (*), din connector, top cover and screws	PVF08 - ../.. (*)	PVF08 - ../.. (*)	PVM06 - ../.. (*)	PVM06 - ../.. (*)	PVM06 - ../.. (*)	PVM06 - ../.. (*)	PVM06 - ../.. (*)
2	Valve Body	M300273	M300274	M300272	M300275	M300279	M300276	M300278
7	Intermediate cover (Double diaphragm)	-	-	M310098	M310098	M310100	M310100	M310101
4	Top Cover	M310142	M310142	M310082	M310082	M310082	M310082	M310082
5	Diaphragm	DB18M	DB18M	DB16	DB16	DB16	DB16	DB16
6	Diaphragm (Secondary)	-	-	DB114	DB114	DB116	DB116	DB120
8	Dresser Nut	M550024	M550026	M550026	M550018	M550018	M550020	M550031
9	Dresser Nut Insert	M620014	M620015	M620015	M620023	M620023	M620033	M620032
10	Conic Seal for Dresser Nut	M330203	M330204	M330204	M330292	M330292	M330310	M330305
11	O-Ring for flanged valve	M330018	M330018	M330019	M330019	M330311	M330311	M330270

(*) Specify Voltage and Frequency

FLANGED VALVE WITH INCREASED FLOW RATE

600 / 700 Series

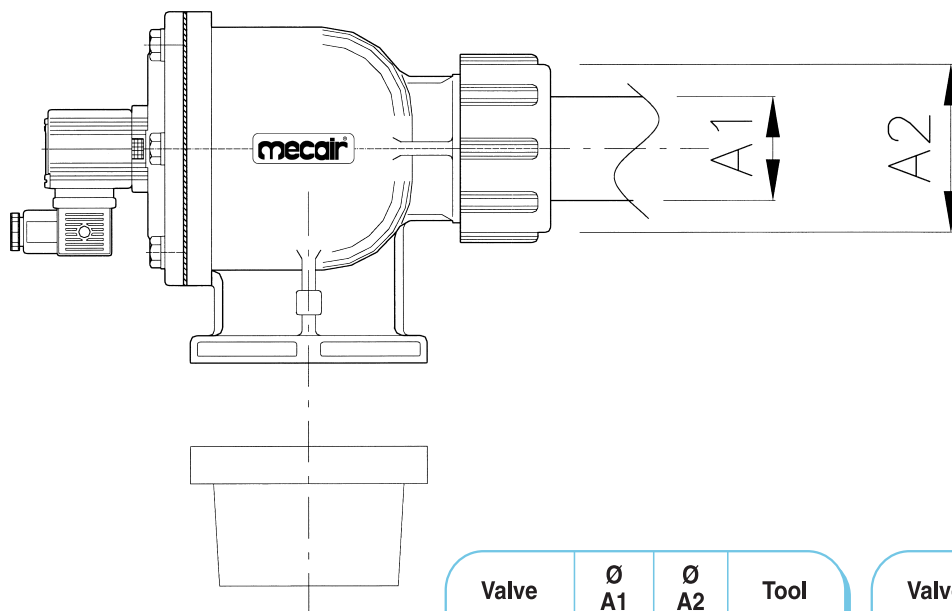

Valve	Ø A1	Ø A2	Tool
608	1"	61	CH08
612	1 1/2"	82	CH14
614	1 1/2"	82	CH14
616	2"	95	CH16
620	2 1/2"	115	CH20

Valve	Ø A1	Ø A2	Tool
708	1 1/2"	82	CH14
712	2"	95	CH16
714	2"	95	CH16
716	2 1/2"	115	CH20
720	3"	128	CH24

MOUNTING TOOL "CH"

MODEL	Ø A1	Ø A2	Ø B	C	D	E	Weight Kg
CH08	1"	61	100	250	350	68	0,44
CH14	1 1/2"	82	130	300	430	85	0,7
CH16	2"	95	150	350	500	100	0,78
CH20	2 1/2"	115	170	350	520	110	0,8

MODEL	Ø A1	Ø A2	Ø B	C	D	E	Weight Kg
CH14	1 1/2"	82	130	300	430	85	0,7
CH16	2"	95	150	350	500	100	0,78
CH20	2 1/2"	115	170	350	520	110	0,8
CH24	3"	128	190	350	540	120	0,9

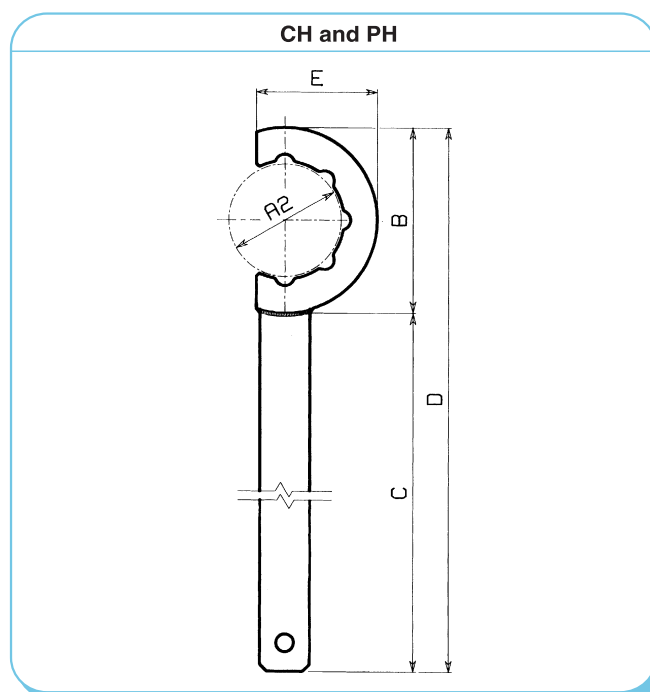

INSTRUCTIONS AND MAINTENANCE

600 / 700 Series

1) - INSTALLATION INSTRUCTIONS

VALVE INLET: Mount valve inlet to flange or flanged pipe - Valve reference Flange "IN".
VALVE OUTLET: To be connected to blowpipe within the filter. Quick Fit connection "OUT".

SEALING OF BLOWPIPE:

Suited to an unthreaded blowpipe only - The blowpipe must enter into the valve body and secured with the dresser nut.

FLUID:

COMPRESSED AIR - Ensure air supply is clean and dry. (We recommend the installation of compressed air filter units to be installed directly before the pressure vessel, in order to ensure clean and dry is supplied to the diaphragm valve). Operating pressure min/max. 0,5 ÷ 7,5 bar.

AIR INLET PIPE TO HEADER TANK/PRESSURE VESSEL:

Minimum Ø 1" for tanks with a 1" valve or 1 1/2" valves.

COMPRESSOR:

With the appropriate compressor size being utilised, this ensures the tank can be refilled from 0-2 bar in a few seconds.

PROTECTION FROM RAIN:

Always ensure a small roof/lid is installed on top of the valves and/or electronic controllers as this protects the valves and controllers from exposure to harsh environmental conditions.

ELECTRICAL ON TIMES AND PULSE TIMES:

Average pulse times range from 100ms - 250ms depending on size of the valves being used.

2) - START UP

Before commencing to pulse the valves and to pressurise the tank/pressure vessel, it is important to eliminate all particulate, including dirt, rust, metal shavings, and other types of particulate, which may eventually enter the piping. The draining of any condensation or liquid within the tank/pressure vessel is also important and should be performed prior to pressurising the system. The drain valve should always be installed and should be used prior to start up. Minimum Ø of the drain valve socket is 1/4". If during the start phase, there is insufficient air in the airline, and you are unable to adequately fill the tank/pressure vessel, (the valves may remain slightly open), it is necessary to close the air inlet valve to the tank, wait for the pressure to reach 6 - 7 bar and then re-open the valve quickly. This will ensure that the tank fills quickly also providing significant pressure which ensures the valves remain properly closed.

3) - SPARE PART RECOMMENDATION

- 3.1 - **FOR START UP** - Minimum quantity of 5% of the supply (min. 1 piece).
 - Pilot Group (pos.1), complete with pilot body, solenoid coil, din connector.
- 3.2 - **FOR THE FIRST TWO YEARS OF OPERATION** - Minimum quantity of 10% of the supply (min. 2 pieces).
 - Pilot Group (pos.1), complete with pilot body, solenoid coil, din connector.
 - Diaphragms (pos.5 and/or 6).

4) - MAINTENANCE AND REPAIRS

4.1 - COMMON PROCESS FOR ALL CONTROLS MAINTENANCE AND REPAIRS TO BE CONDUCTED:

- Before conducting any maintenance activity on the system ensure that the components are fully isolated from pressure and power supplies
- Replacement or controls relating to diaphragms (pos.5), in reinstalling/re-positioning the diaphragm ensure that the diaphragm bleed is in the correct position lined up with the valve body position. The bleed should fit into the valve body eyelet.
- Secure the bolts on the top cover to the valve body without over tightening. We recommend the use of a torque wrench to properly secure the bolts: **1,6 kgm** for M6 (3/4" - 1"), **3,8 kgm** for M8 (1 1/2") and **7 kgm** for M10 (2" - 2 1/2" - 3").
- Substitution of or controls relating to the solenoid pilot: Prior to removing the solenoid pilot, ensure power supply is disconnected. Remove carefully din socket and then remove solenoid coil.

4.2 - PERIODICAL MAINTENANCE - Annually check:

- In the case of VNP/VXP models, check the integrity of the electrical connections and the din socket connection to be properly fixed to the solenoid coil.
- In the case of VEM models, check the integrity of all pneumatic connections including pneumatic piping and all pneumatic connections.

4.3 - MALFUNCTION / TROUBLE SHOOTING: - Proceed with controls and checks below:

DEFECT / FAULT	CONTROL / CHECKS
The valve does not open or vibrates	<ul style="list-style-type: none"> - Verify integrity of the solenoid or that the wires are not damaged. - Verify that the electrical connections are properly connected to the valve and that the wiring has been performed correctly. - Verify that the outlets from the electronic controller are free from disturbances and within the specified tolerances of +/-10% of the nominal value.
The valve remains opens or loses air continuously	<ul style="list-style-type: none"> - Check that the bolts of the top cover are properly secured, in case of diaphragm substitution. - Remove the top cover and verify that there are no particulate underneath the diaphragm.